



ACCII Upgrade Kit

UnwiredTools, LLC
2200 East Cedar #1
Flagstaff, AZ 86004
www.unwiredtools.com

UnwiredTools ACCII Upgrade Kit™ Installation Guide and Owner's Manual

Important Notes:

- This is a new version of the product. If you have installed an ACCII Kit before please note that the preferred mounting location is now the OEM servo bracket.
- **The Diagnostic Lights are now visible from the outside of the case.**
- The vacuum lines are designed to plug into the OEM rubber vacuum connector.
- The installation time for this kit is approximately 2 hours, not including any time to find and fix vacuum leaks unrelated to the installation of this product.
- If you have blower function on DEF but not on Auto-Hi or Auto-Lo then you have a vacuum leak. Call us for advice and documentation. We're here to help.





ACCII Upgrade Kit

UnwiredTools, LLC
2200 East Cedar #1
Flagstaff, AZ 86004
www.unwiredtools.com

Printed in the U.S.A.
Copyright © 2004-2012 *UnwiredTools, LLC*
All Rights Reserved.

NOTICE REGARDING WARRANTIES

The *UnwiredTools* ACCII Upgrade Kit™ comes with a Limited Warranty, a copy of which appears on the back of this Manual. With regard to this Manual and the information in it (the “Manual”), please note that, although UnwiredTools has endeavored to make it as accurate and informative as possible, the variability of vehicles, the circumstances of installation, changes from year to year, and other factors make it impossible for UnwiredTools to guarantee that this information is accurate and/or directly applicable for your vehicle and your particular circumstances. The information in this Manual therefore is provided as a general guide or illustration. It is your responsibility and not that of UnwiredTools to ensure that this Product is suitable for your vehicle and that it meets your needs or requirements. This Manual is provided “as is” and without any warranties of any kind. UnwiredTools makes no representations or warranties with respect to this Manual, e.g., as to its accuracy, completeness or appropriateness to any particular vehicle or situation. UNWIREDTOOLS HEREBY DISCLAIMS ANY AND ALL WARRANTIES AS TO THIS MANUAL, EXPRESS OR IMPLIED, INCLUDING BUT NOT LIMITED TO THE IMPLIED WARRANTIES OF MERCHANTABILITY AND FITNESS FOR A PARTICULAR PURPOSE. UNWIREDTOOLS ALSO DISCLAIMS ANY LIABILITY FOR YOUR USE OF THE MANUAL. PLEASE USE IT AT YOUR OWN RISK. This Manual may be updated from time to time. Users are encouraged to visit our Web site at www.unwiredtools.com to obtain the latest version, to obtain information about the Product, and to obtain other support information.

NOTICE REGARDING TRADEMARKS

UnwiredTools™ and UnwiredTools ACCII Upgrade Kit™ are trademarks of UnwiredTools, LLC. All other trademarks referred to herein are the marks of their respective companies, and not of UnwiredTools.



ACCII Upgrade Kit

UnwiredTools, LLC
2200 East Cedar #1
Flagstaff, AZ 86004
www.unwiredtools.com

WARNING: READ BEFORE BEGINNING INSTALLATION

The *UnwiredTools* ACCII Upgrade Kit TM installs into vehicles for which it is designed, and couples into hot water lines, electrical systems, and vacuum lines. Please be aware that improper handling, installation or use can cause damage to your vehicle, other property, and even injury, grave harm or worse to you and others. Please follow the instructions set out in this Manual where they are applicable to your vehicle. If you are in doubt or have questions, contact a qualified service representative.

1. Read this entire Manual before beginning installation.
2. Check all kit components to make sure that all appear undamaged.
3. Make sure your vehicle is off, and is cool. Ensure that it is immobilized, e.g., in park with the emergency brake engaged.
4. Ensure that your work area is free of any circumstances that could result in electrical shock. All power tools and electrical cables should be properly grounded. Keep floors and other areas dry if electrical equipment is being used.
5. Ensure that there is nothing loose or unconnected before the vehicle is started

Important Note:

Note: This kit is intended for professional installation. A trained technician will have the documentation, tools, and training needed to find and fix vacuum leaks or wiring problems in your vehicle which may interfere with the function of this product. Professional installers familiar with this product may be found under the Support section of www.unwiredtools.com.



Table of Contents

Contents of the UnwiredTools ACCII Upgrade Kit™	...5
Product Description6
Theory of Operation7
Overview of Installation8
Step-by-Step Installation9
Troubleshooting Guide24
System Vacuum Diagram26
Revision History27
Warranty28



ACCII Upgrade Kit

UnwiredTools, LLC
2200 East Cedar #1
Flagstaff, AZ 86004
www.unwiredtools.com

Contents of the UnwiredTools ACCII Upgrade Kit™

Please check the contents of this package to make sure it is complete. Your kit should include the following:

- 1 ea Digital controller
- 1 ea Hot water valve,
- 1 ea 90° water hose
- 1 ea copper return tube
- 1 ea Hardware Kit

Recommended Tools:

- Phillips screwdriver (long and short profile)
- Multi-meter
- Needle Nose Pliers
- Utility Knife
- Wire Cutters
- Socket Set
- Vacuum Gauge (only needed if you have a vacuum leak)

Hardware kit contents:

- 2 ea of 4" and 2 ea of 8" plastic wire ties
- 2 ea 3" lengths of 7/64" ID vacuum tubing
- 3 each jumpers for the Servo Amplifier connections
- 1 ea vacuum "4-Way" connector
- 1 ea vacuum "3-way" T connector
- 1 ea vacuum "U" connector
- 2 each 1/16" to 1/8" barbed tubing reducer for the controller vacuum line (YEL,BLK)
- 3 each of 1/6" vacuum connectors, for the controller vacuum lines (WHT,PUR,BLU)
- 1 ea 1/8" vacuum plug



ACCII Upgrade Kit

UnwiredTools, LLC
2200 East Cedar #1
Flagstaff, AZ 86004
www.unwiredtools.com

The UnwiredTools ACCII Upgrade Kit™ upgrades the unreliable analog and mechanical ACCII Climate Control System to modern digital microprocessor technology. This upgrade replaces both the OEM servo and the OEM amplifier with rugged, industrial strength solenoid valves and a proprietary Controller module.



The UnwiredTools ACC II Upgrade Kit™ restores your ACCII system to better than original function.

The features of this upgrade include the following:

- For all Mercedes 107, 116, and 123 chassis models with ACCII Climate Control
- Eliminates expensive and unreliable mechanical servo
- Eliminates analog amplifier module, no more overheating of module
- Keeps OEM controls and the “factory” look
- No more running down the battery due to a stuck servo
- Integrates into existing A/C vacuum and electrical system
- Two hour installation time*
- Less expensive and more reliable than rebuilt servos
- No Core Exchange Required
- One year limited warranty

*Time does not include repairing faulty vehicle vacuum systems. If you suspect your vehicle has a vacuum leak, it is recommended that you have a professional install this kit in your vehicle.



Theory of Operation

The OEM Servo and Amplifier work in conjunction with three sensors to regulate the temperature in your ACCII Climate Control System. The three sensors are the thumb wheel in the console, the cabin temperature, and the outside air temperature. These values act as inputs to the Servo, which then selectively: controls fan speeds, opens and closes flaps, and meters the flow of hot water into the heater core. The OEM Servo and Amplifier is a complex collection of electrical, mechanical and vacuum connections and controls. The temperature value on the console thumbwheel is known as the “set-point”. The job of the Climate Control System is to regulate the temperature to maintain the cabin pressure as close as possible to the set-point. Unless turned off with the dash switch, the Air Conditioning compressor is always running. When the set-point is higher than the current cabin temperature, hot water is passed into the heater core, to raise the temperature, easily over-powering the air conditioning and delivering the desired set-point temperature.

The UnwiredTools ACCII Upgrade Kit™ (KIT) provides the same regulated climate control functionality as delivered by the OEM system, but uses reliable, modern technology and also has an enhanced regulation control algorithm.

The KIT monitors the position of the console thumbwheel to determine the desired cabin temperature. When the inside temperature differs from the set-point, the KIT opens or closes the vacuum-actuated hot water valve. This difference sets the fan speed. When the difference is large, the fan speeds up. As the temperature approaches the set-point, the fan speed slows, creating a comfortable climate control environment in the vehicle. Special hardware and software works around most reliability problems found in the sensor chain, namely intermittent open connections and bad ground points.

The OEM look and feel is retained but with vastly improved performance over the OEM Servo.



Installation Overview

Installing the UnwiredTools ACCII Upgrade Kit™ (KIT) includes the following steps:

1. Take inventory of any current problems with the vehicle's vacuum system. If there are any known vacuum leaks (outside of the Servo itself), they should be repaired prior to installation.
2. Remove of the glove box liner.
3. Remove of OEM Servo Amplifier and plug in the jumpers.
4. Test thumbwheel sensor connection.
5. Remove of OEM Servo.
6. Installation of Hot Water Valve and Return Tube.
7. Mount the Controller Box.
8. Install Vacuum & Electrical Connections
9. Tidying Up
10. Diagnostics



ACCII Upgrade Kit

UnwiredTools, LLC
2200 East Cedar #1
Flagstaff, AZ 86004
www.unwiredtools.com

1. A Quick Word on Vacuum Leaks

The best practice is to find and fix any vacuum leaks before proceeding. Leaks generally are easy to find if you have a vacuum diagram and know where to find the vacuum actuators and switches. **Access to some actuators is time consuming. A difficult to reach actuator may be better capped and left in place than replaced. Call UnwiredTools for troubleshooting assistance.**

We have developed a number of detailed, color coded, vacuum diagrams which are available free of charge. These diagrams were created from careful study of the OEM diagrams as well as experience and feedback from professional technicians. Additional vacuum and electrical diagrams for your ACCII equipped vehicle are available from our website:

<http://unwiredtools.com/accii.html>

The next steps of the installation walk you through removing the glove box liner where you gain access to the vacuum bundle, as shown here. If you need to test or patch around individual vacuum circuits, this is a handy place to cut, test and re-join with a piece of tubing if needed. The next photo shows a leg vent actuator on a 123 chassis. You should be comfortable with working with the vacuum system. If this is beyond your skill set or comfort level, we highly recommend that you take your KIT and vehicle to an experienced professional mechanic. If you need assistance locating a mechanic in your area, we can help. Our website has a database of shops familiar with our product line. You can find this list here:

<http://unwiredtools.com/shops.asp>

If your system has leaks there will be no vacuum source when the ACCII system is turned on. A minimum of vacuum of 6 in-Hg is needed to operate the system. A common troubleshooting practice is to **temporarily** use a known good vacuum source until the vacuum leak is repaired. Shown here is temporarily tapping into a vacuum hose in the engine bay.

Vacuum diagrams for your vehicle are available for download at:

<http://unwiredtools.com/vacuum>

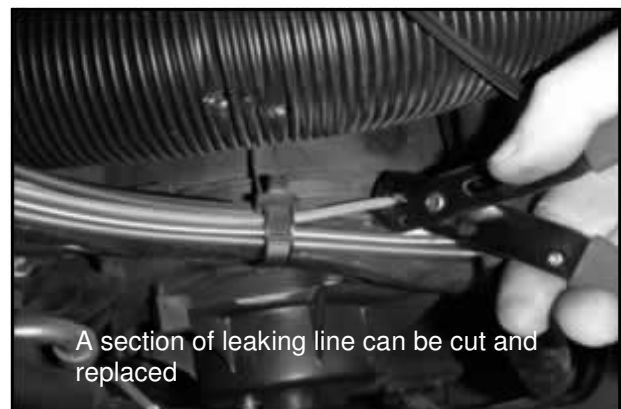

A section of leaking line can be cut and replaced



A new line section is fitted to a leg actuator



A new line section being spliced into the vacuum harness



2. Controller Mounting Location

This version of the Controller in the ACCII Upgrade Kit is designed to mount on the OEM servo bracket, shown at right.



Aux Water Pump

It's common to find alarm systems under the hood or behind the glove box liner. These systems can often be the source of poorly grounded connections or wiring damage. If these systems are no longer required, consider removing them to gain access to good mounting locations for the KIT's Controller Box.



3. Removal of the glove box liner

The installation of the UnwiredTools™ ACCII Upgrade Kit begins inside the car by removing the liner for the glove box. The liner is held in place by 2-piece expanding plastic plug fasteners. Depending on your model vehicle, there are up to seven of these fasteners. Remove the fasteners by inserting a small, thin flat-blade screwdriver under the upper head of the plug. Gently pry the head up then pull it out. When the upper piece is pulled out the expanding plug can be removed. Work slowly and gently. These fasteners get brittle with age.

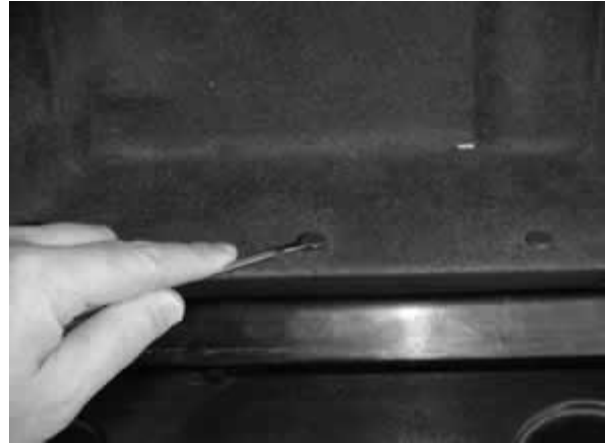

Next remove the 2 screws which hold the glove box latch in place. These screws are oriented vertically and there is little clearance. A very short screwdriver or a 1/4" ratchet drive screwdriver will be needed.



You can also remove the glove box door to gain additional space to maneuver. This is done by removing the Philips head screws attached to the hinges and the screws attached to the sides of the door. Be sure to keep track of all these pieces for reassembly!

The glove box light can be removed by inserting a thin screwdriver edge at the front then gently prying down and toward the rear. When the light is removed from its hole the glove-box liner may be removed.





4. Removal of the Servo Amplifier

When the glove box liner is removed, the servo control amplifier can be accessed and removed. The amplifier is held in place by two Philips-head screws. **Note:** On 107 chassis models, the servo amp is located on the transmission tunnel side, not the passenger door side.



With the Servo Amplifier removed, our next task is to install jumpers across terminals of the Amplifier connector. The connector is keyed so you can determine which side is position 1. There are a total of eight positions on the connector. Obtain the 3 jumpers found in the Electrical Hardware Kit. Install jumpers across positions 1 to 2, 3 to 5, and 7 to 8 as shown below.

Servo Amplifier Jumpers:

Jumper pins 1-2, 3-5, and 7-8

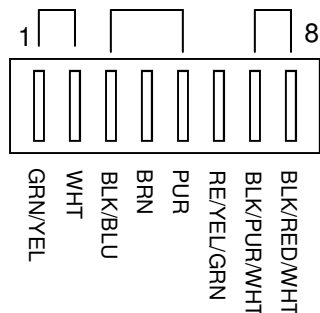

← These wire colors are for the wires in the car. These colors are shown for orientation.



5. Testing Thumbwheel Sensor

The next step is to verify that the thumbwheel sensor connection is OK and that your thumbwheel is in proper operating condition. The thumbwheel sensor is a variable resistor, so we will test by checking the resistance read with a multi-meter set to Ohms. Probe pins 2 and 3 of the OEM Servo electrical connector as shown. These are the PUR and RED/GRN wires leading into the connector as shown.

Measure the resistance when the thumbwheel is at 85. Then measure the resistance at 65. **The difference between the 2 readings should be at least 1200 Ohms.**

If the resistance reads ∞ or open then there's an open connection in the sensor chain.

If the cabin temperature regulates too high or too low after the installation is complete then the thumbwheel can easily be calibrated. Remove the fascia plate and the front panel from the ACCII control panel as shown below. The front panel is held by a hooked plastic clip on the right and left side. Gently push these clips aside with a small screwdriver. Be careful, these clips are fragile. On the right side of the thumbwheel is a toothed or square plate. Use a small screwdriver to hold the plate while you turn the thumbwheel.



Note: on 116 chassis vehicles the thumbwheel assembly is held onto the front wood panel with wooden blocks. The glue holding these wooden blocks falls apart with age so you'll have to re-glue the blocks to the wooden fascia with epoxy before re-assembly.



Calibrating the thumbwheel, 107 chassis



6. Remove the Vacuum connector

Remove the vacuum connector from the OEM Servo. Note that this rubber connector for the vacuum lines is secured to the OEM Servo with one screw which is accessible from the back side, the same side where the vacuum lines enter the connector. Remove the screw and pull out the connector. When the connector is removed from the servo it should look like the photo shown here.

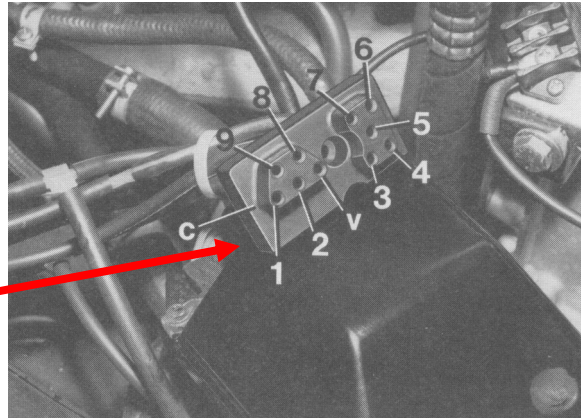

Vacuum Connector Block
port numbers

7. Removing the OEM Servo & Installing Hot Water Valve

In this step, the OEM Servo is removed from your vehicle. The four water (coolant) lines at the bottom of the Servo can be plugged with corks as the lines are removed. If you plug these lines as you remove them, then coolant loss will be minimal and the heater system should not have to be bled. Use the reference picture to the right to identify the feed and return sides of the OEM Servo. You may want to tag those lines prior to removing them from the OEM Servo. This will assist you in the next step after the OEM Servo is removed. Be sure to keep the hose clamps, as these are re-used in most circumstances. Once the coolant lines are identified, remove the OEM Servo by removing the **2 bolts** holding it to the bracket.



Feed Side
(Water to Core)

Return Side
(From Core)



ACCII Upgrade Kit

UnwiredTools, LLC
2200 East Cedar #1
Flagstaff, AZ 86004
www.unwiredtools.com

7. Removing the OEM Servo & Installing Hot Water Valve, Continued

After the OEM Servo is removed, the Hot Water Valve supplied in the KIT is installed on the feed side pair of hoses. Carefully note the orientation of the water valve. The **black** side of the new Hot Water Valve connects to the aux water pump. This installation step varies by chassis types:

107 Chassis Installations: Use the 90° bend hose as shown in the top picture. The 90° bend hose attaches to the black side of the Hot Water Valve and the aux water pump.

116/123 Chassis Installations: A straight hose is needed, not the 90° bend hose supplied in this kit. The 90° bend hose can be trimmed with a razor blade as shown.

Regardless of the chassis type, the **black** side of the Hot Water Valve installs towards the aux water pump.

The return tube supplied in the KIT is connected between the hoses on the return side. Again, use the reference picture on the previous page to properly identify the return side hose connections.

Make sure the hose clamps are secure.

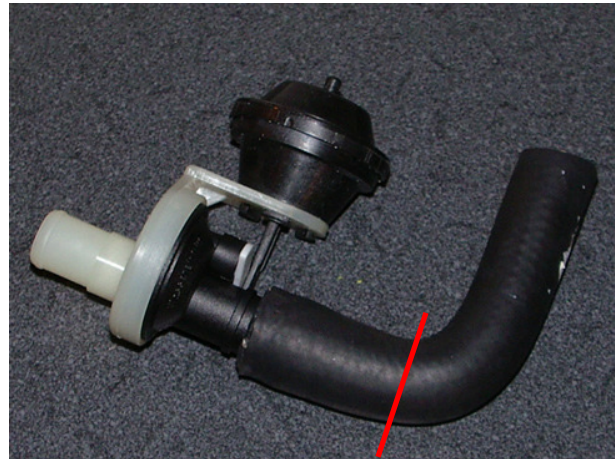

This side connects to heater core

Trim hose here for 116/123 chassis



107 installation

Water Valve
The BLACK side faces the aux water pump



Hot Water Controls

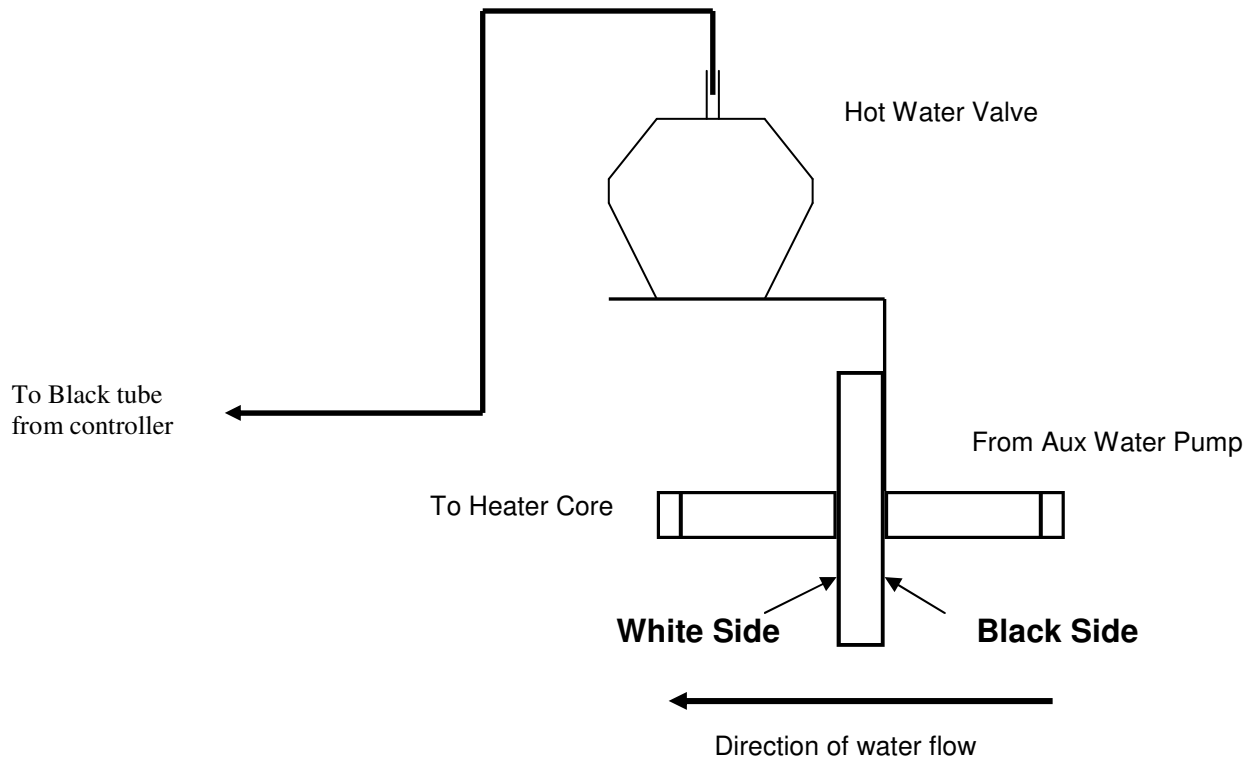

Note: The Black side MUST face toward the auxiliary water pump. If this valve is installed backward it will not turn completely off!



8. Installing Hot Water Valve, Continued

The vacuum source for the hot water valve is the Yellow line to the Controller Box. This line must be connected to a constant vacuum source, like the vacuum reservoir. This is important because the source of vacuum in most gas engine cars is the intake manifold. The intake manifold vacuum goes low when the engine is under load. Under these conditions the intake manifold vacuum alone may not be enough to keep the hot water valve closed. All Mercedes vehicles with the ACCII system have a vacuum reservoir to prevent this problem.

The photo at right shows the 3-way connector which joins the YEL and YEL/GRY vacuum lines together. This junction is connected to the vacuum reservoir. Connect the vacuum source of the hot water valve to this junction

The photo here was taken behind the brake booster on the Driver's side. This is a handy place to tap into the vacuum reservoir in a 116 or 123 chassis. Shown here is a 4-way connector in place of the OEM 3-way connector. The black tube shown here was installed to carry the constant vacuum of the reservoir to the other side of the car where the Controller Box is located. Don't confuse the black line shown in the photo with the black line to the controller. The black line in this photo is only there to connect the controller to the constant vacuum source. The Black line shown in this photo will be connected to the Yellow line of the Controller Box.

In 107 chassis cars the vacuum reservoir is located inside the passenger front fender. The photo here shows the YEL/GRY vacuum line penetrating the fender next to the coolant tank. This vacuum line may be yellow, yellow with a grey stripe, or grey with a yellow stripe. This location is much closer to the controller so it is a much more convenient place to tap into the vacuum reservoir. **Note: The hardware kit contains a vacuum T and some tubing to make this connection.**

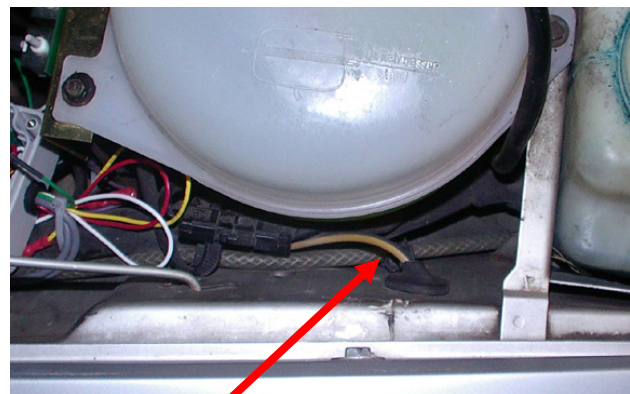
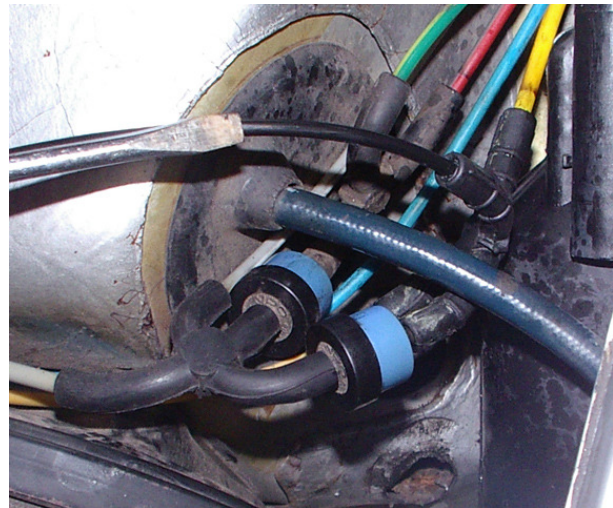
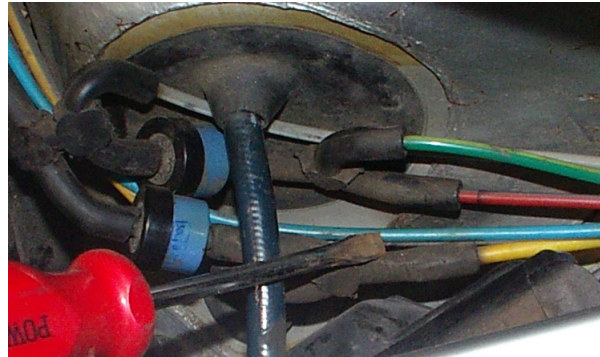

Vacuum reservoir line



8. Mounting the Controller Box

The Controller Box is designed to be secured to the bracket that held the OEM servo. The new version of the ACCII Controller is small and light and this procedure call for securing the controller using tie-wraps. If desired, the bracket may be drilled to bolt the controller to the bracker. We suggest removing the bracket first if you intent to drill it.

The right side tie wrap will go through this hole

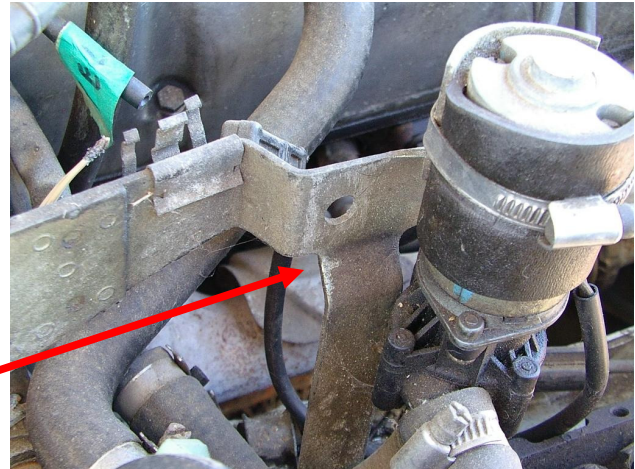

Pass the right side tie wrap through the center hole of the Controller, then through the hole in the Servo bracket. The tie wrap will wrap around the bracket and engage the upper hole on the right side of the controller.



The left side simply wraps around the bracket as shown.

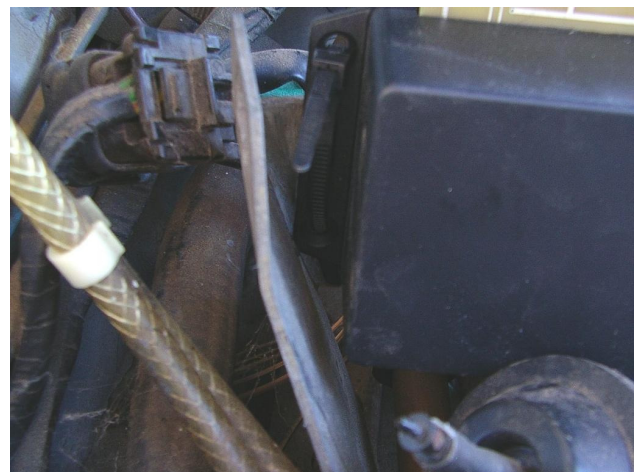



9. Vacuum & Electrical Connections

We are now ready to make the necessary vacuum and electrical connections. The step by step instructions are below and your connections should be compared to the diagram found on the following page. The instructions refer to positions rather than color, so be sure to use your color chart to make sure you have the correct vacuum lines.



NOTE: Spray the car's vacuum connector with a light coating of synthetic lubricant before inserting any of the vacuum lines. This will make it easier to remove the connections in the future.

1. Plug in the vacuum 4-way connector in the car's rubber connector block.
2. Plug in the blue, white, and purple vent control lines from the controller into the connector block.
3. Connect the Yellow line from the Controller box to a constant vacuum source, preferably the vacuum reservoir.
4. Connect the Black line from the Controller Box to the Hot Water Valve
5. When you removed the OEM Servo, there were two vacuum lines, yellow and black, which connected to the Thermo Switch located beneath the Servo. Connect these two lines together with a "U".



NOTE: The Controller Box does not have the ability to turn off the Blower nor does it control the A/C Compressor Clutch. If the Blower or the A/C compressor are not operating normally then there's a vacuum leak. The GREEN vacuum circuit requires at least 6in Hg to turn on the blower. Call UnwiredTools if you have any questions about troubleshooting the vacuum system.



9. Vacuum Connections:

Plug in the vacuum “4-way” connection into ports 1, 2, 3, and 4 as shown.

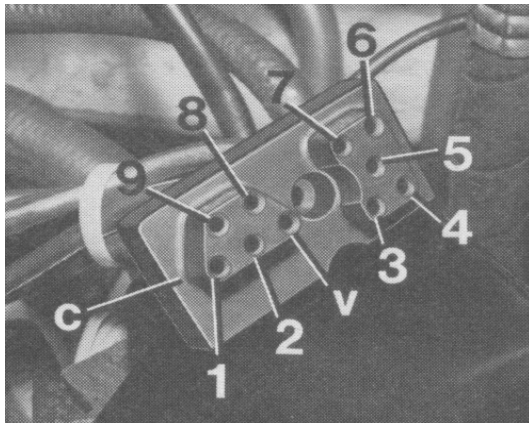

Plug the BLUE line into port 8.

Plug the PURPLE line into port 7. Port 6 and Port 7 are joined together with a 3-way vacuum connection in the car’s vacuum harness. In order to prevent a vacuum leak Port 6 must be plugged. The nylon plug in the hardware kit is provided to plug Port 6. Port 6 is the **circled** port in the picture on the right.

Plug the WHITE line into port 5.

NOTE: The vacuum connections described above disable the recirculation flap function and leave it permanently in the “fresh air position”. On 123 chassis models in hot and humid climates it may be beneficial to restore the function of recirculation flap. Please contact UnwiredTools support for instructions on how to do this.

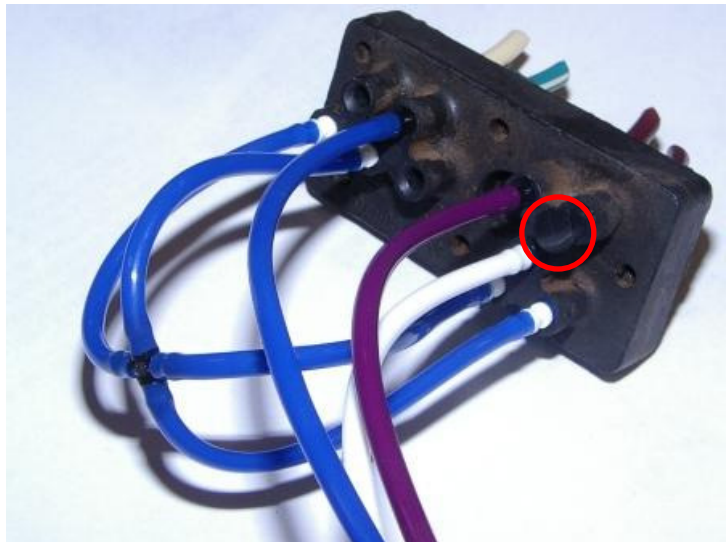



9. Vacuum Connections Continued:

The following is a summary of the vacuum connections. The locations of the vacuum connector port numbers are also shown in the photograph on page 14. When you're done the vacuum connections should look like this:

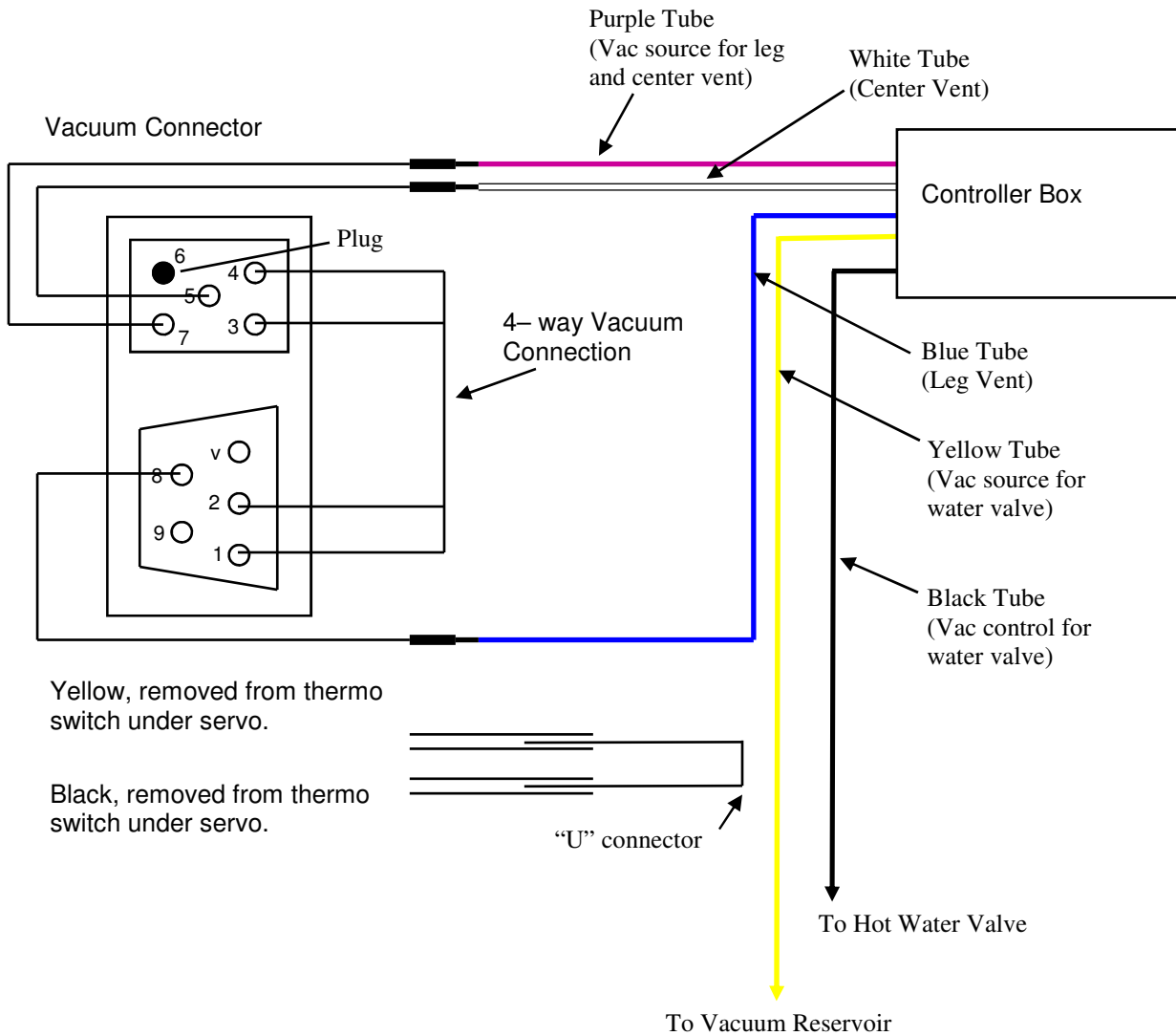



ACCII Upgrade Kit

UnwiredTools, LLC
2200 East Cedar #1
Flagstaff, AZ 86004
www.unwiredtools.com

9. Electrical Connections

Locate the "Fan and Power" wiring harness. There are 10 pins. **The pin on the far left is pin 1.** Plug in the one-piece wiring connector so that the colors match up as follows:

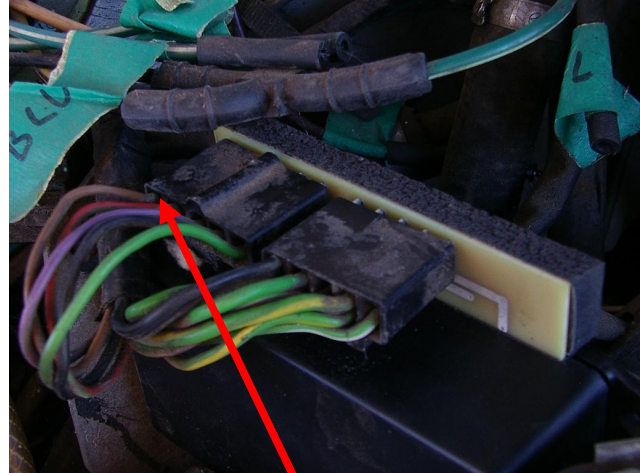

Pin 1 Brown wire

Mercedes Servo Connector
10 pins, 1/4" female fast-ons
Embedded in 2 plastic housings

Mercedes Wire Colors:

BRN	1	□
RED/GRN	2	□
PUR	3	□
BLK	4	□
GRN	5	□
BLK	6	□
GRN	7	□
GRN/RED	8	□
GRN/YEL	9	□
GRN/WHT	10	□

ACCII Controller:

□	GND
□	Sensor Chain
□	GND
□	+12V
□	Defrost
□	FAN-COMMON
□	FAN4
□	FAN3
□	FAN5
□	



ACCII Upgrade Kit

UnwiredTools, LLC
2200 East Cedar #1
Flagstaff, AZ 86004
www.unwiredtools.com

12. Tidying Up

Your UnwiredTools ACCII Upgrade Kit™ contains plastic wire-ties in the Vacuum Hardware Kit. These are useful for cleaning up the installation by securing the vacuum and electrical connections into tidy bundles. Be careful not to tighten the wire ties too much around the vacuum lines, otherwise you might impact the vacuum flow. Check your coolant level, replace your glove box liner and enjoy your new ACCII Upgrade Kit!



12. Test and Troubleshooting

The UnwiredTools™ ACCII controller is fully tested at the factory. Although failures may occur, they are infrequent and generally easy to spot. **Call us if you are having trouble finding a vacuum leak.**

Test:

Testing the installation is quick and easy by following these steps:

1. Run the car until the engine coolant is warm, temp gauge > 60°C.
2. Press “DEF”. The blower should run at maximum and the air should become hot. The vacuum hot water valve should fully open and stay open. Allow the car’s interior to become fully warm, at least several minutes.
3. Press “Auto Lo” or “Auto-Hi”. Roll the temperature dial to fully cold, 65°F. The hot water valve should fully close and the blower should run at maximum. The center vents should be open and the leg vents should be closed. The interior temperature of the car should start cooling down. As the interior becomes cooler the blower speed should decrease. Allow the interior to cool for several minutes. The temperature of the air coming out of center vents should be less than 55°F (AC Compressor on).
4. When the blower speed decreases in the previous step then increase the temperature dial to 75°F. The hot water should start to pulse in less than 2 minutes, indicating that the controller is within range of a temperature lock and regulation has been achieved.

Q. When I press “Auto Lo” or “Auto Hi” nothing happens, the blower does not turn on but the blower does turn on when “DEF” is pressed.

A. The blower is powered when vacuum appears at the main vacuum switch (switch 19 on the diagram, page 26). Check for vacuum here. When you press “Auto Lo” or “Auto Hi”, the black line connected to the 4-way vacuum connector becomes the vacuum source for the system. Check that there is vacuum on the black vacuum line. The system requires 6in-Hg or more of vacuum for the system to operate properly. If the vacuum is OK, then check the wiring connections and the fuse. **Make sure power is getting to the controller by measuring with a volt meter between the red and black wire on the ACCII Upgrade Kit Wiring Harness.**

Q. When I press “Auto-Lo” or “Auto-Hi” the fuse blows.

A. This indicates a possible defect in the wiring harness. Check to make sure that the connectors are tight and none of the wires are pinched.

If you have a vacuum leak or you have any questions regarding your installation please feel free to call our tech support line, **928-773-0469 #802**. We’re here to help and we’re looking forward to helping whenever we can,



ACCII Upgrade Kit

UnwiredTools, LLC
2200 East Cedar #1
Flagstaff, AZ 86004
www.unwiredtools.com

Self-Diagnostic Function

The UnwiredTools ACCII Upgrade Kit™ uses a powerful microcontroller to make the heating and air conditioning functions as comfortable as possible. Most of these functions are fully automatic. Automatic functions can be complex and confusing so indicators are included with this product to quickly and easily troubleshoot any problems. To view the diagnostic indicators simply remove the base plate which holds the Controller PCB.

The ACCII Upgrade Kit has 3 operating modes which are can be summarized as follows:

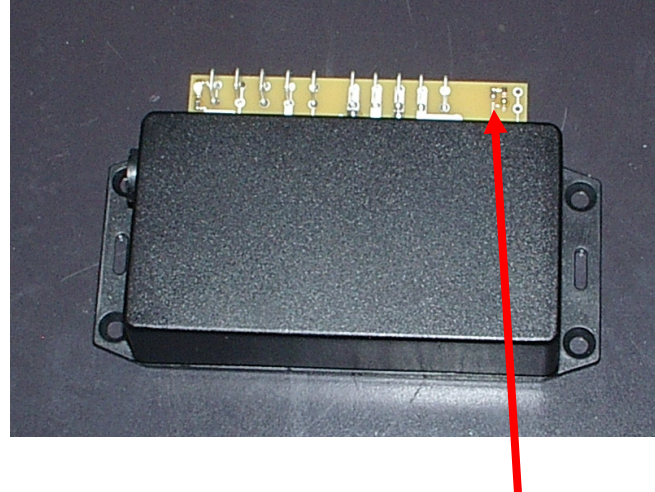

Status Indicator, YELLOW color

Max Cool -Center vent on, Leg vent off, Hot Water valve off, blower at maximum.

Normal Operation -Center vent may be on or off, Leg vent on or off, Hot Water valve pulses, blower at any setting, controller is regulating, hot water valve is pulsing.

Max Heat -Center vent off, Leg vent on, Hot Water valve off, blower at maximum.

There are 7 indicator lights inside the ACCII Upgrade Kit controller. To gain access to these lights simply remove the base plate from the controller. These indicators are shown in the photo.

The status indicator flashes a code every 8 seconds. The status indicator flash codes are as follows:

- Normal operation 1 flash
- Sensor Chain Fault 2 flashes
- Defrost Mode 3 flashes

The Defrost mode is active when the DEF button is pressed. The indicator lights should function as follows:

Mode	Leg Vent	Center Vent	Hot Water Valve
Max Cool	Off	On	Off
Inside temp near set temp	Off	Off	Pulsing
Max Heat	On	Off	On



ACCII Upgrade Kit

UnwiredTools, LLC
2200 East Cedar #1
Flagstaff, AZ 86004
www.unwiredtools.com

Diagnosing Sensor Chain Problems:

If the system runs and the installation appears to be working but the temperature is too hot or too cold then the fast way to verify how things are working is to monitor the sensor chain. An indicator is supplied to check the calibration of the sensor chain.

The UnwiredTools ACCII Upgrade Kit™ connects the Thumbwheel, the inside air temp sensor, and outside air temp sensor in series. Mercedes designed these 3 sensors so that when they are in agreement the voltage on pin 2 of the connector will be 2.5V. The Sensor Chain Indicator Light will illuminate when the sensor chain is 2.5V, +/- 0.05V.

To check the sensor chain simply turn the key on (engine off) and press "Auto-Hi". Now roll the temperature wheel up and down slowly until the red light lights up. Now look down at the temperature wheel. The reading on the temperature wheel is the temperature that is reported by sensor chain to the controller.

Compare this reading to the actual temperature in the car. Measure the temp at the in-car temp sensor. The temperature wheel can be calibrated if the error is less than 10 degrees. If the error is greater than call UnwiredTools for more information.

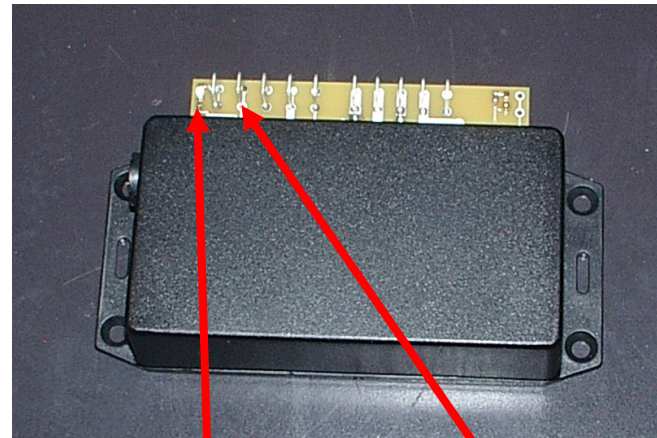

Sensor Chain Indicator Light, RED color

Sensor Chain Signal voltage, pin 2

Use the RED sensor chain indicator light to check the sensor chain calibration. You will need an accurate thermometer for this step. The thermometer is used to compare the temperature reported by the sensor chain to the actual temperature

Note: If the sensor chain voltage is greater than 2.5V then the system is in HEAT mode. If less than 2.5V then COOLING mode.

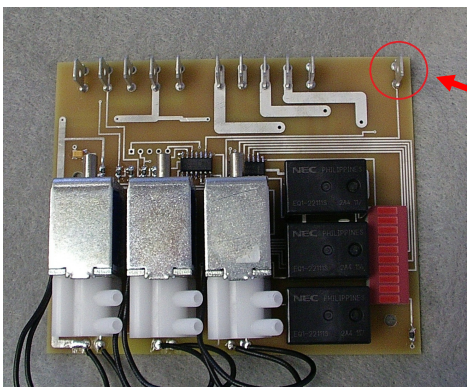

Note: This connector is for a soon to be announced fan boost feature which increases the power of the AC system by more than 50%. For more information see our website. Leave it unconnected if this feature is not used.



ACCII Upgrade Kit

UnwiredTools, LLC
2200 East Cedar #1
Flagstaff, AZ 86004
www.unwiredtools.com

ACCII Vacuum Diagram, After Kit Installation

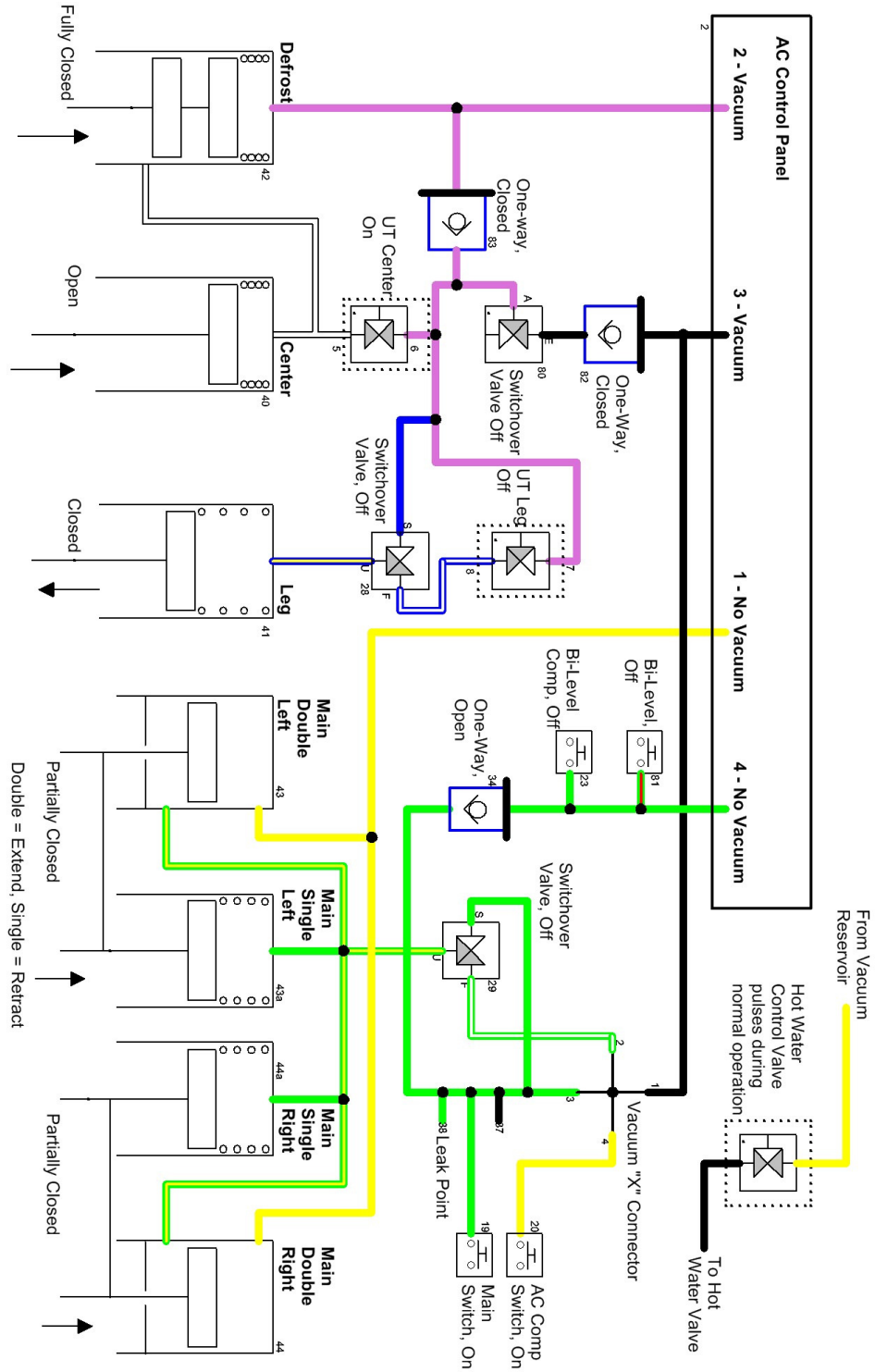



ACCII Manual Revision History

Date	Revision	Description
01/01/08	J1	Changed various vacuum connector descriptions
02/28/08	J2	Added suggestion to spray the vacuum connector with lubricant before inserting into the rubber connector of the car.
05/14/08	J3	Added installation cautions on cover page
06/09/08	J4	Added page for Diagnostic Lights
12/09/08	J5	Removed single vacuum connector. Added detail on vacuum Connections
06/11/09	J6	Added plug to hardware kit to plug port 6 and removed instructions to remove three way connection on page 20. Replaced picture on page 20 to show plug in Port 6.
08/05/09	J7	Corrected hardware kit contents. Changes to warranty page
10/09/09	J8	Correction to hardware kit contents
10/14/10	J9	Changed photo of PCB on diagnostic page to match new revision
10/02/11	J10	Corrected list of materials in hardware kit
03/20/12	K0	Improved smaller version
07/05/12	K2	Fixed error in the diagnostic light legend on page 25.
10/15/12	K4	Added photo of boost connector
01/07/13	K5	New hardware kit list
02/20/13	K6	Diagnostic Lights now visible from outside

Support:

Please visit <http://unwiredtools.com> for the latest product and support information. You can join the UnwiredTools support forum and view the latest manuals and tech notes as well as find an installer in your area.



ACCII Upgrade Kit

UnwiredTools, LLC
2200 East Cedar #1
Flagstaff, AZ 86004
www.unwiredtools.com

UNWIREDTOOLS Limited Warranty

UNWIREDTOOLS, LLC ("UT") warrants that your new UnwiredTools™ ACCII Upgrade Kit ("Product") is free from defects in materials and workmanship at the time of manufacture. This warranty extends for a period of ONE YEAR from the date of purchase of the original Product. If there is a defect in or malfunction of this Product that is covered by this warranty, UT will repair the Product free of charge as follows: PARTS: New or comparable rebuilt parts will be provided in exchange for defective parts. LABOR: You will not be charged for labor required by UT to make the necessary repairs under this warranty. UT is not responsible, however, for any other labor charges, for example, such as those attributable to removing the Product from your vehicle or reinstalling it in your vehicle. This warranty does not include normal wear and tear, tubing, wiring connector, or other parts which may wear or fail as a result of normal use. This warranty also does not include any defect or failure of any kind arising from improper installation, improper use, neglect, abuse, accident, or any cause other than defects in materials and workmanship at the time of manufacture. This warranty applies only to the original purchaser of the Product from UT or an authorized distributor or reseller. It does not apply to persons who purchased this Product second hand or used.

TO OBTAIN SERVICE UNDER THIS WARRANTY, the Product must be delivered to a UT Authorized Service Center nearest to your location; or the Product must be shipped postage prepaid, insured and via a traceable shipping method to a UT Authorized Service Center or to the UT Corporate Service Center at 2200 East Cedar Avenue, Suite 1, Flagstaff, Arizona 86004. You must:

- Pack your Product in the original carton or equivalent.
- Enclose a copy of the bill of sale or invoice showing original purchase date and seller. (Please note that you should retain the original proof of purchase for your records to establish date of original purchase. Your warranty starts with the date of original purchase.)
- Enclose a card or note describing in detail the difficulty you are experiencing with the Product.
- Be sure to include your complete name, address and daytime telephone number. In addition, please include your e-mail address if you agree to permit UT to contact you through it.
- Bring or ship, prepaid and insured, via a traceable shipping method, the above Product to the nearest UT Authorized Service Center location or to the UT Corporate Service Center.

Please note that UT will NOT pay return postage, shipping or insurance, so you will need to make arrangements for this. Products repaired or replaced pursuant to this warranty will be returned to the address identified as the sender unless another address is provided. The UT and/or the Service Center cannot be held responsible for any loss or damage that occurs while in transit or outside our control.

OTHER THAN THE EXPRESS WARRANTIES PROVIDED HEREIN, THERE ARE NO OTHER WARRANTIES, EXPRESS OR IMPLIED. UT HEREBY EXPRESSLY DISCLAIMS ALL SUCH OTHER WARRANTIES, INCLUDING BUT NOT LIMITED TO THE WARRANTIES OF MERCHANTABILITY AND FITNESS FOR A PARTICULAR PURPOSE. UT SHALL NOT BE LIABLE FOR ANY SPECIAL, INDIRECT, CONSEQUENTIAL, INCIDENTAL, OR EXEMPLARY DAMAGES OF ANY KIND, INCLUDING BUT NOT LIMITED TO SUCH DAMAGES RESULTING FROM ANY FAILURE, DEFECT, OR MALFUNCTION OF THIS PRODUCT, EVEN IF UT IS NOTIFIED OF THE POTENTIAL FOR SUCH DAMAGES. UT'S LIABILITY UNDER THIS WARRANTY SHALL BE LIMITED TO REPAIR OR REPLACEMENT OF THE PRODUCT OR A REFUND OF YOUR ORIGINAL PURCHASE PRICE FOR THE PRODUCT. Some states do not allow limitations on how long an implied warranty lasts and some states do not allow the exclusion or limitation of incidental or consequential damages, so the above limitations or exclusions may not apply to you. This warranty gives you specific legal rights, and you may also have other rights which vary from State to State. This warranty is valid only for Products delivered and used in the United States. Your purchase of this Product, or installing or using the Product, will be deemed acceptance of this Limited Warranty and Remedies Limitation as set forth here. If you do not accept these and do not intend to be bound by them, please return the Product in its original packaging as you received it to your original point of purchase for a full refund of your purchase price.

To find the nearest Authorized Service Centers within your local area, see our Web site at www.unwiredtools.com, or you may call the UT Corporate Service Center directly at 928-773-0469.

rev. 053105
